

**DV36**  
**DV45**  
**Tier 4A (interim)**  
Vibratory Roller

**DV45CC**  
**Tier 4A (interim)**  
Combination Roller

## SERVICE MANUAL

**Part number 48142070**

1<sup>st</sup> edition English

September 2017

*Replaces part number 47538933*

**CASE**  
CONSTRUCTION



## **SERVICE MANUAL**

**DV36  
DV45CC  
DV45**

# Contents

---

## INTRODUCTION

Maintenance .....	00
[00.150] Start-up .....	00.1
Engine.....	10
[10.001] Engine and crankcase .....	10.1
[10.400] Engine cooling system .....	10.2
Hydrostatic drive.....	29
[29.218] Pump and motor components .....	29.1
Brakes and controls .....	33
[33.110] Parking brake or parking lock .....	33.1
[33.202] Hydraulic service brakes .....	33.2
Hydraulic systems.....	35
[35.104] Fixed displacement pump .....	35.1
[35.000] Hydraulic systems .....	35.2
[35.102] Pump control valves.....	35.3
[35.353] Hydraulic travel system .....	35.4
[35.300] Reservoir, cooler, and filters.....	35.5
[35.995] Compaction/vibration hydraulic system .....	35.6
Frames and ballasting .....	39
[39.100] Frame .....	39.1
Steering.....	41
[41.101] Steering control .....	41.1
Wheels .....	44
[44.160] Compaction drums .....	44.1
Electrical systems .....	55
[55.031] Parking brake electrical system .....	55.1

[55.000] Electrical system .....	55.2
[55.019] Hydrostatic drive control system .....	55.3
[55.100] Harnesses and connectors.....	55.4
[55.408] Warning indicators, alarms, and instruments .....	55.5
[55.512] Cab controls.....	55.6
[55.640] Electronic modules .....	55.7
[55.404] External lighting .....	55.8
[55.DTC] FAULT CODES.....	55.9
<b>Tools .....</b>	<b>89</b>
[89.165] Water kit.....	89.1
<b>Platform, cab, bodywork, and decals .....</b>	<b>90</b>
[90.100] Engine hood and panels .....	90.1
[90.110] Operator platform less cab .....	90.2





## INTRODUCTION

# Contents

---

## INTRODUCTION

Safety rules .....	3
Safety rules - Ecology and the environment .....	4
Safety rules - Shop and assembly .....	5
Safety rules - Hydraulic contamination .....	7
Personal safety .....	8
Basic instructions - Important notice regarding equipment servicing .....	9
Torque .....	10
Special tools .....	13
Capacities .....	21
Consumables .....	22

---

## Safety rules

### Personal safety





This is the safety alert symbol. It is used to alert you to potential personal injury hazards. Obey all safety messages that follow this symbol to avoid possible death or injury.

Throughout this manual you will find the signal words DANGER, WARNING, and CAUTION followed by special instructions. These precautions are intended for the personal safety of you and those working with you.

Read and understand all the safety messages in this manual before you operate or service the machine.

 DANGER indicates a hazardous situation that, if not avoided, will result in death or serious injury.

 WARNING indicates a hazardous situation that, if not avoided, could result in death or serious injury.

 CAUTION indicates a hazardous situation that, if not avoided, could result in minor or moderate injury.

### **FAILURE TO FOLLOW DANGER, WARNING, AND CAUTION MESSAGES COULD RESULT IN DEATH OR SERIOUS INJURY.**

### Machine safety

**NOTICE:** Notice indicates a situation that, if not avoided, could result in machine or property damage.

Throughout this manual you will find the signal word Notice followed by special instructions to prevent machine or property damage. The word Notice is used to address practices not related to personal safety.

### Information

**NOTE:** Note indicates additional information that clarifies steps, procedures, or other information in this manual.

Throughout this manual you will find the word Note followed by additional information about a step, procedure, or other information in the manual. The word Note is not intended to address personal safety or property damage.



---

## Safety rules - Ecology and the environment

When legislation does not yet rule the treatment of some of the substances required by advanced technology, sound judgment should govern the use and disposal of products of a chemical and petrochemical nature.

**NOTE:** *The following are recommendations that may be of assistance:*

- Become acquainted with and ensure that you understand the relative legislation applicable to your country.
- Where no legislation exists, obtain information from suppliers of oils, filters, batteries, fuels, antifreeze, cleaning agents, etc., with regard to their effect on man and nature and how to safely store, use, and dispose of these substances.

### Helpful hints

- Avoid filling tanks using cans or inappropriate pressurized fuel delivery systems that may cause considerable spillage.
- In general, avoid skin contact with all fuels, oils, acids, solvents, etc. Most of them contain substances that may be harmful to your health.
- Modern oils contain additives. Do not burn contaminated fuels and or waste oils in ordinary heating systems.
- Avoid spillage when draining off used engine coolant mixtures, engine, gearbox and hydraulic oils, brake fluids, etc. Do not mix drained brake fluids or fuels with lubricants. Store them safely until they can be disposed of in a proper way to comply with local legislation and available resources.
- Modern coolant mixtures, i.e. antifreeze and other additives, should be replaced every two years. They should not be allowed to get into the soil, but should be collected and disposed of properly.
- Repair any leaks or defects in the engine cooling or hydraulic system immediately.
- Do not increase the pressure in a pressurized circuit as this may lead to a component failure.
- Protect hoses during welding as penetrating weld splatter may burn a hole or weaken them, allowing the loss of oils, coolant, etc.

---

## **Safety rules - Shop and assembly**

### **O-ring seals**

Lubricate the O-ring seals before you insert them in the seats. This will prevent the O-ring seals from overturning and twisting, which would jeopardize sealing efficiency.

### **Sealing compounds**

Apply a sealing compound on the mating surfaces when specified by the procedure. Before you apply the sealing compound, prepare the surfaces as directed by the product container.

### **Spare parts**

Only use CNH Original Parts.

Only genuine spare parts guarantee the same quality, duration, and safety as original parts, as they are the same parts that are assembled during standard production. Only CNH Original Parts can offer this guarantee.

When ordering spare parts, always provide the following information:

- Machine model (commercial name) and Product Identification Number (PIN)
- Part number of the ordered part, which can be found in the parts catalog

---

## Protecting the electronic and/or electrical systems during charging and welding

To avoid damage to the electronic and/or electrical systems, always observe the following practices:

1. Never make or break any of the charging circuit connections when the engine is running, including the battery connections.
2. Never short any of the charging components to ground.
3. Always disconnect the ground cable from the battery before arc welding on the machine or on any machine attachment.
  - Position the welder ground clamp as close to the welding area as possible.
  - If you weld in close proximity to a computer module, then you should remove the module from the machine.
  - Never allow welding cables to lie on, near, or across any electrical wiring or electronic component while you weld.
4. Always disconnect the negative cable from the battery when charging the battery in the machine with a battery charger.

**NOTICE:** *If you must weld on the unit, you must disconnect the battery ground cable from the machine battery. The electronic monitoring system and charging system will be damaged if this is not done.*

5. Remove the battery ground cable. Reconnect the cable when you complete welding.

## Special tools

### WARNING

**Battery acid causes burns. Batteries contain sulfuric acid.**

**Avoid contact with skin, eyes or clothing. Antidote (external): Flush with water. Antidote (eyes): flush with water for 15 minutes and seek medical attention immediately. Antidote (internal): Drink large quantities of water or milk. Do not induce vomiting. Seek medical attention immediately.**

**Failure to comply could result in death or serious injury.**

W0111A

The special tools that CASE CONSTRUCTION suggests and illustrate in this manual have been specifically researched and designed for use with CASE CONSTRUCTION machines. The special tools are essential for reliable repair operations. The special tools are accurately built and rigorously tested to offer efficient and long-lasting operation.

By using these tools, repair personnel will benefit from:

- Operating in optimal technical conditions
- Obtaining the best results
- Saving time and effort
- Working in safe conditions

---

## Safety rules - Hydraulic contamination

Contamination in the hydraulic system is a major cause of the malfunction of hydraulic components. Contamination is any foreign material in the hydraulic oil.

Contamination can enter the hydraulic system in several ways:

- When you drain the oil or disconnect any line
- When you disassemble a component
- From normal wear of the hydraulic components
- From damaged seals or worn seals
- From a damaged component in the hydraulic system

All hydraulic systems operate with some contamination. The design of the components in this hydraulic system permits efficient operation with a small amount of contamination. An increase in this amount of contamination can cause problems in the hydraulic system.

The following list includes some of these problems:

- Cylinder rod seals that leak
- Hydraulic oil that becomes too hot
- Pump gears, housing, and other parts that wear rapidly
- Relief valves or check valves held open by dirt
- Quick failure of components that have been repaired
- The machine does not have enough power.

If your machine has any of these problems, check the hydraulic oil for contamination.

There are two types of contamination: microscopic and visible.

Microscopic contamination occurs when very fine particles of foreign material are suspended in the hydraulic oil. These particles are too small to see or feel. Microscopic contamination can be found by identification of the following problems or by testing in a laboratory.

Examples of problems caused by microscopic contamination:

- Cylinder rod seals that leak
- The hydraulic system has a high operating temperature

Visible contamination is foreign material that can be found by sight, touch, or odor. Visible contamination can cause a sudden failure of components.

Examples of problems caused by visible contamination:

- Particles of metal or dirt in the oil
- Air in the oil
- Dark or thick oil
- Oil with an odor of burned oil
- Water in the oil

If you find contamination, use a portable filter to clean the hydraulic system.

---

## Personal safety

Wear Personal Protective Equipment (PPE) such as hard hat, eye protection, heavy gloves, hearing protection, protective clothing, etc.

Wear working footwear with non-slip soles. Smooth soles may slip from steps and pedals resulting in injury or incorrect operation.

Wear closely fitting work clothes when operating the machine. Loose, wide garments may result in the control lever being inadvertently activated.

Keep clear of moving parts. Loose clothing, jewelry, watches, long hair, and other loose or hanging items can become entangled in moving parts.

Do not smoke or use an open flame when at work.

Always wear eye protection when working with batteries.

Do not create sparks or have an open flame near the battery.

Hydraulic oil or diesel fuel leaking under pressure can penetrate the skin, causing serious injury or infection.

- Do not use your hand to check for leaks. Use a piece of cardboard or paper.
- Stop engine, remove key and relieve the pressure before connecting or disconnecting fluid lines.
- Make sure all components are in good condition and tighten all connections before starting the engine or pressurizing the system.
- If hydraulic fluid or diesel penetrates the skin, seek medical attention immediately.
- Continuous long term contact with hydraulic fluid may cause skin cancer. Avoid long term contact and wash the skin promptly with soap and water.

---

## **Basic instructions - Important notice regarding equipment servicing**

All repair and maintenance work listed in this manual must be carried out only by qualified dealership personnel, strictly complying with the instructions given, and using, whenever possible, the special tools.

Anyone who performs repair and maintenance operations without complying with the procedures provided herein shall be responsible for any subsequent damages.

The manufacturer and all the organizations of its distribution chain, including - without limitation - national, regional, or local dealers, reject any responsibility for damages caused by parts and/or components not approved by the manufacturer, including those used for the servicing or repair of the product manufactured or marketed by the manufacturer. In any case, no warranty is given or attributed on the product manufactured or marketed by the manufacturer in case of damages caused by parts and/or components not approved by the manufacturer.

The information in this manual is up-to-date at the date of the publication. It is the policy of the manufacturer for continuous improvement. Some information could not be updated due to modifications of a technical or commercial type, or changes to the laws and regulations of different countries.

In case of questions, refer to your CASE CONSTRUCTION Sales and Service Networks.

## Torque

**NOTICE:** The screws can loosen due to the vibration of the roller!  
Unless otherwise specified, secure all screws with **LOCTITE® 242®**.

The values below apply:

- Unless otherwise specified in the manual
- To female steel threads

### Hexagon screws/bolts and hexagon-socket-head cap screws

AF size hexagon	AF size hexagon socket	Screw diameter	Steel quality	Tightening torque
7	3	M4	8.8	3 N·m (2.2 lb ft)
8	4	M5	8.8	6 N·m (4.4 lb ft)
10	5	M 6	8.8	10 N·m (7.4 lb ft)
13	6	M 8	8.8	25 N·m (18.4 lb ft)
13	6	M 8	10.9	36 N·m (26.6 lb ft)
15	-	M 10 x 1.25	10.9	90 N·m (66.4 lb ft)
17	8	M 10	8.8	48 N·m (35.4 lb ft)
19	10	M 12	8.8	84 N·m (62.0 lb ft)
19	10	M 12	10.9	123 N·m (90.7 lb ft)
19	-	M 14 x 1.5	10.9	246 N·m (181.4 lb ft)
22	12	M 14	8.8	133 N·m (98.1 lb ft)
24	14	M 16	8.8	206 N·m (151.9 lb ft)
24	-	M 16	10.9	302 N·m (222.7 lb ft)
30	-	M 20	8.8	415 N·m (306.1 lb ft)
30	-	M 20	10.9	592 N·m (436.6 lb ft)

### Extremely low-profile cheese-head screws

Allen key size	Screw diameter	Steel quality	Tightening torque
3	M 5	10.9	3 N·m (2.2 lb ft)
3	M 6	10.9	6 N·m (4.4 lb ft)
4	M 8	10.9	13 N·m (9.6 lb ft)
5	M 10	10.9	25 N·m (18.4 lb ft)

### Flanged oval-head screws

Allen key size	Screw diameter	Steel quality	Tightening torque
2.5	M 4	10.9	2.5 N·m (1.8 lb ft)
3	M 5	10.9	5 N·m (3.7 lb ft)
4	M 6	10.9	8 N·m (5.9 lb ft)
5	M 8	10.9	12 N·m (8.9 lb ft)

### Countersunk head screws

Allen key size	Screw diameter	Steel quality	Tightening torque
3	M 5	10.9	3.8 N·m (2.8 lb ft)
4	M 6	10.9	6.6 N·m (4.9 lb ft)
5	M 8	10.9	16 N·m (11.8 lb ft)

### Shoulder screws

Allen key size	Screw diameter	Steel quality	Tightening torque
6	M 10	12.9	43 N·m (31.7 lb ft)

**Operator seat, seat belt fastening screws**

AF size hexagon key	Screw diameter	Steel quality	Tightening torque
5/8"	UNF 7/16"	8.8	45 N·m (33.2 lb ft)

**Drain cock**

Drain cock	
Diesel tank	Secure the screw connections with <b>LOCTITE® 565™ PST</b> and tighten by hand, not with torque.
Hydraulic tank	Secure the screw connections with <b>LOCTITE® 565™ PST</b> and tighten by hand, not with torque.

**Threaded bolt for ROPS joint**

Screw diameter	Steel quality	Tightening torque
M 18	S355	147 N·m (108.4 lb ft) ( 30 kg (66 lb) on 50 cm (20 in) lever)
Grease with <b>LOCTITE® ANTI-SEIZE</b> lubricating compound, for example.		

**Threaded adapters / Metric threads**

Thread size	Cutting ring	Soft seat ring	Nominal joint size	
M10x1.0	18 N·m (13.3 lb ft)	18 N·m (13.3 lb ft)	6	L
M12x1.5	25 N·m (18.4 lb ft)	25 N·m (18.4 lb ft)	8	L
M14x1.5	45 N·m (33.2 lb ft)	45 N·m (33.2 lb ft)	10	L
M16x1.5	55 N·m (40.6 lb ft)	55 N·m (40.6 lb ft)	12	L
M18x1.5	70 N·m (51.6 lb ft)	70 N·m (51.6 lb ft)	15	L
M22x1.5	125 N·m (92.2 lb ft)	125 N·m (92.2 lb ft)	18	L
M26x1.5	180 N·m (132.8 lb ft)	180 N·m (132.8 lb ft)	22	L
M33x2.0	310 N·m (228.6 lb ft)	310 N·m (228.6 lb ft)	28	L
M12x1.5	35 N·m (25.8 lb ft)	40 N·m (29.5 lb ft)	6	S
M14x1.5	55 N·m (40.6 lb ft)	40 N·m (29.5 lb ft)	8	S
M16x1.5	70 N·m (51.6 lb ft)	70 N·m (51.6 lb ft)	10	S
M18x1.5	110 N·m (81.1 lb ft)	90 N·m (66.4 lb ft)	12	S
M20x1.5	150 N·m (110.6 lb ft)	125 N·m (92.2 lb ft)	14	S
M22x1.5	170 N·m (125.4 lb ft)	135 N·m (99.6 lb ft)	16	S
M27x1.5	270 N·m (199.1 lb ft)	180 N·m (132.8 lb ft)	20	S

**Threaded adapters / Inch threads**

Thread size	Cutting ring	Soft seat ring	Nominal joint size	
1/8"	18 N·m (13.3 lb ft)	18 N·m (13.3 lb ft)	6	L
1/4"	25 N·m (18.4 lb ft)	25 N·m (18.4 lb ft)	8	L
1/4"	45 N·m (33.2 lb ft)	45 N·m (33.2 lb ft)	10	L
3/8"	55 N·m (40.6 lb ft)	55 N·m (40.6 lb ft)	12	L
1/2"	70 N·m (51.6 lb ft)	70 N·m (51.6 lb ft)	15	L
1/2"	125 N·m (92.2 lb ft)	125 N·m (92.2 lb ft)	18	L
3/8"	180 N·m (132.8 lb ft)	180 N·m (132.8 lb ft)	22	L
1"	310 N·m (228.6 lb ft)	310 N·m (228.6 lb ft)	28	L
1/4"	35 N·m (25.8 lb ft)	40 N·m (29.5 lb ft)	6	S
1/4"	55 N·m (40.6 lb ft)	40 N·m (29.5 lb ft)	8	S
3/8"	70 N·m (51.6 lb ft)	70 N·m (51.6 lb ft)	10	S
3/8"	110 N·m (81.1 lb ft)	90 N·m (66.4 lb ft)	12	S
1/2"	150 N·m (110.6 lb ft)	125 N·m (92.2 lb ft)	14	S
1/2"	170 N·m (125.4 lb ft)	135 N·m (99.6 lb ft)	16	S
3/4"	270 N·m (199.1 lb ft)	180 N·m (132.8 lb ft)	20	S



## INTRODUCTION

---

**NOTE:** *To tighten hydraulic hoses and fittings:*

*Screw the union nut by hand all the way to the stop, then tighten  $\frac{1}{4}$  of a turn with the wrench ( **90°** )*

## Special tools

Assembly tool, pressure plate for puller for the drive bearing flange clamp ring

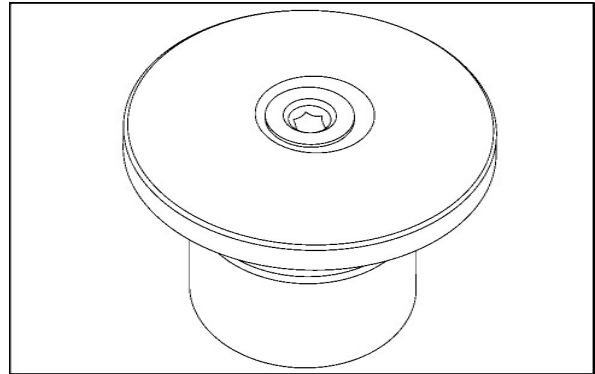

SVIL13SPT0583AB 1

Assembly tool, puller for the drive bearing flange clamp ring

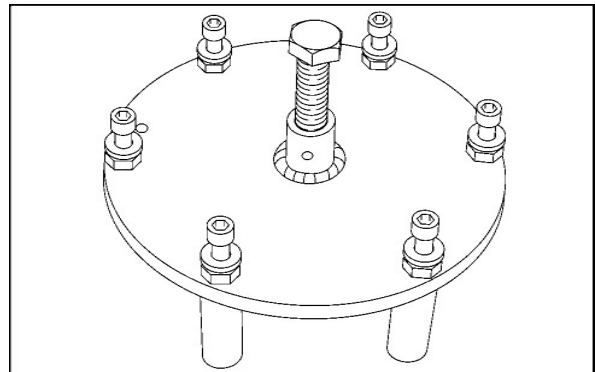

SVIL13SPT0584AB 2

Assembly tool for pendulum joint

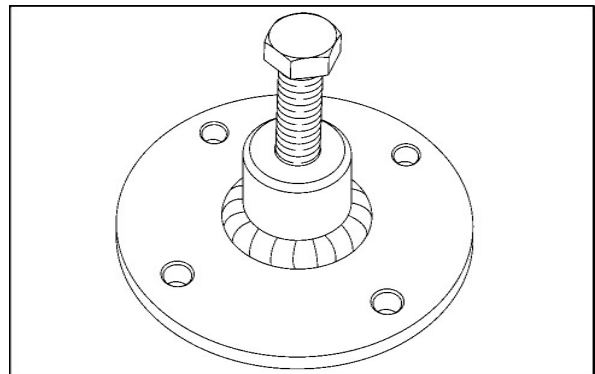

SVIL13SPT0585AB 3

Assembly tool for vibro shaft (1)  
M12 eye bolt not included in scope of delivery

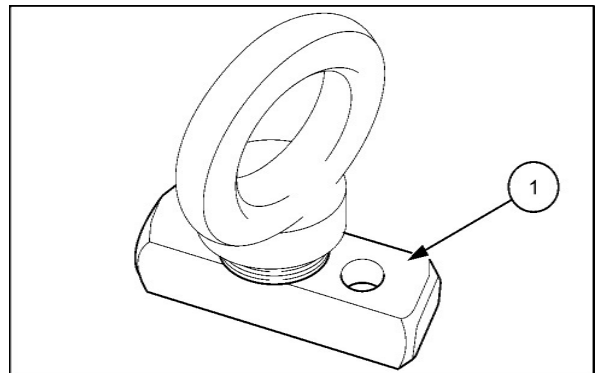

SVIL13SPT0586AB 4

# INTRODUCTION

Assembly tool, support sleeve for vibro bearing (in drive bearing flange)

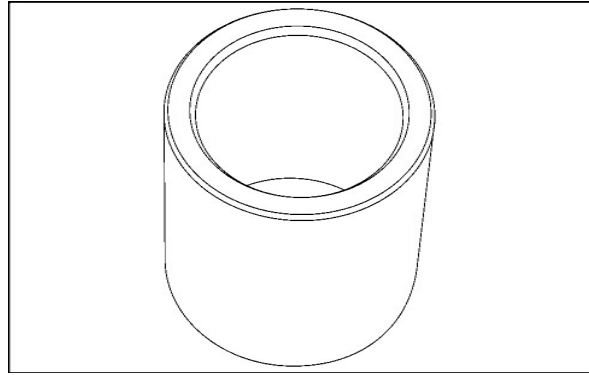

SVIL13SPT0590AB 5

Assembly tool, press-in sleeve for vibro bearing

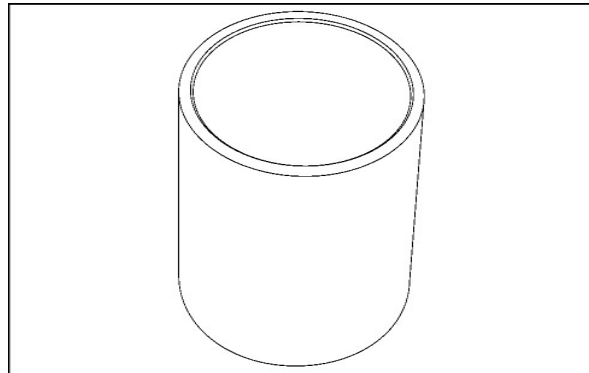

SVIL13SPT0595AB 6

Assembly tool for steering cylinder

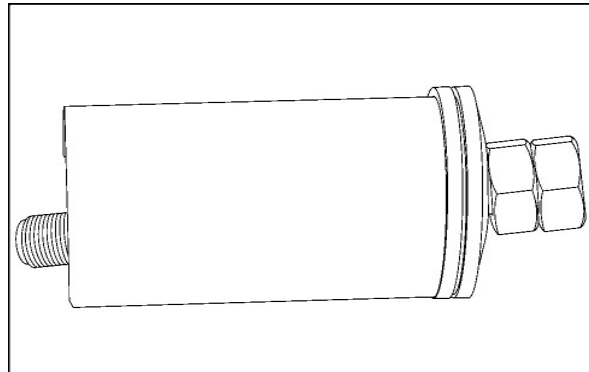

SVIL13SPT0591AB 7

Assembly tool for drive bearing

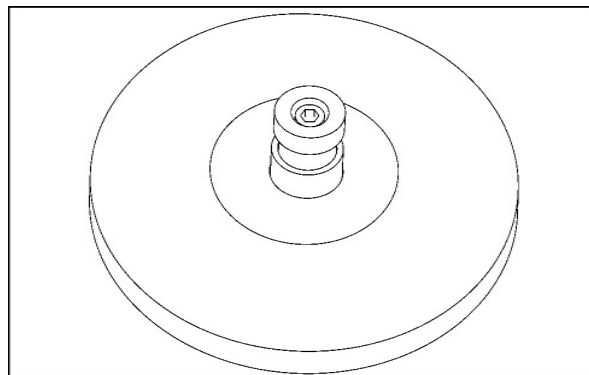

SVIL13SPT0596AB 8

# INTRODUCTION

Assembly tool for shaft sealing ring

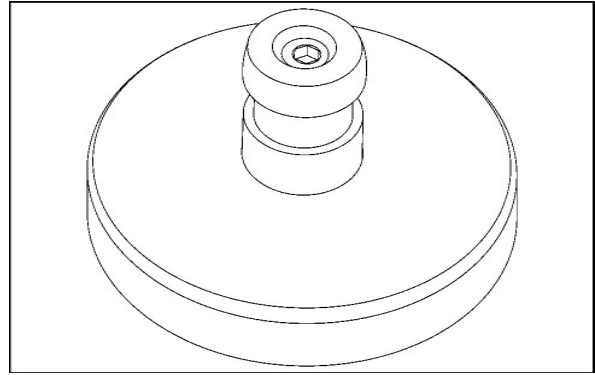

SVIL13SPT0597AB 9

Assembly tool for pinion fastener

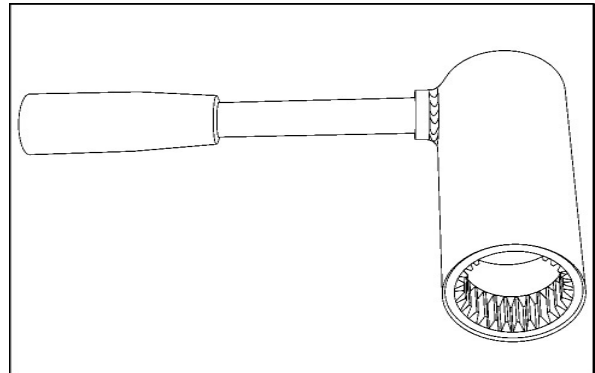

SVIL13SPT0598AB 10

Assembly tool, pressure plate for drive bearing flange

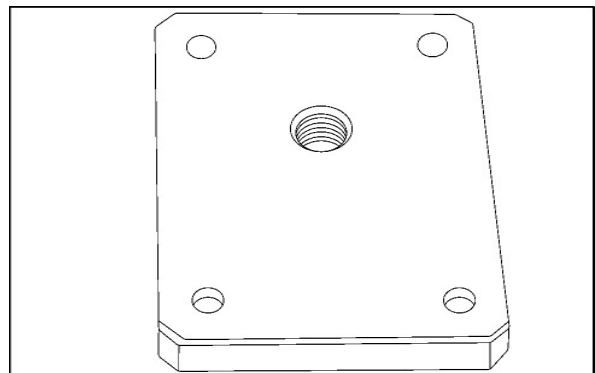

SVIL13SPT0601AB 11

Assembly tool, pressure plate for drive bearing flange with M16 eye bolt

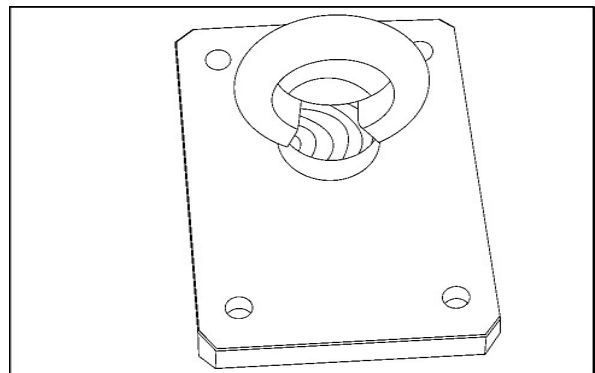

SVIL13SPT0600AB 12

# INTRODUCTION

Assembly tool, pressure plate for drive bearing flange with M16 bolt

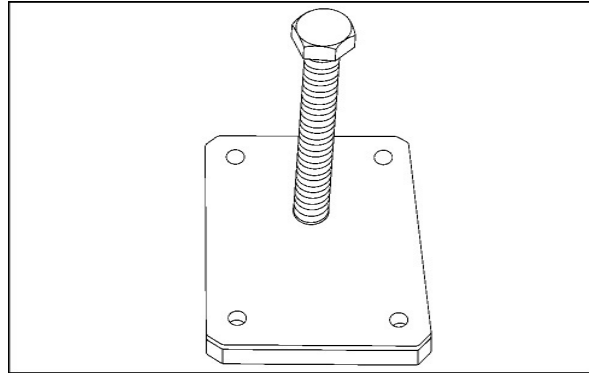

SVIL13SPT0602AB 13

Assembly tool for vibro shaft

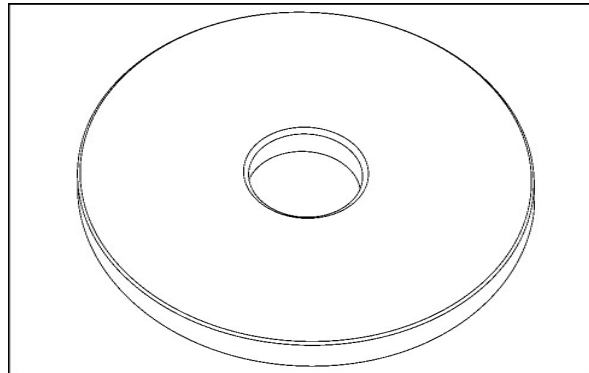

SVIL13SPT0603AB 14

Puller tool for pendulum support bolts

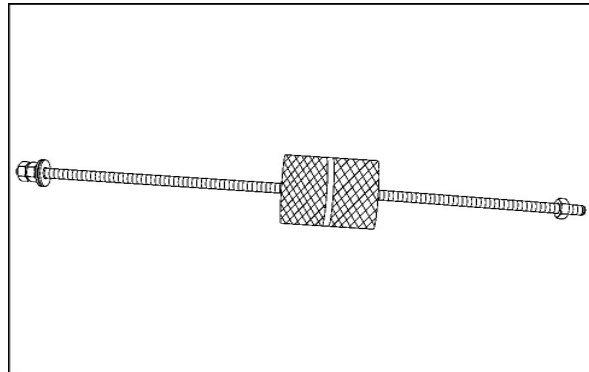

SVIL13SPT0604AB 15

Special wrench for rear wheel support fastening bolts

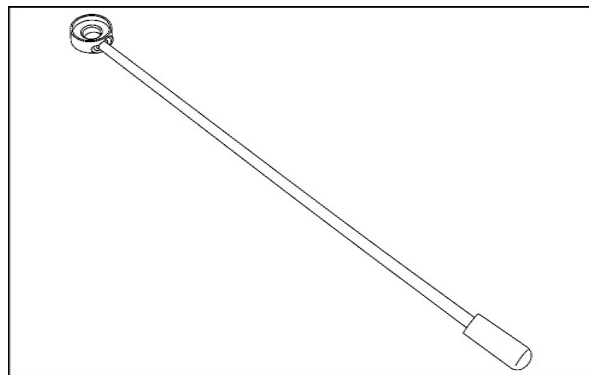

SVIL13SPT0605AB 16

# INTRODUCTION

Special wrench for rear wheel support fastening bolts

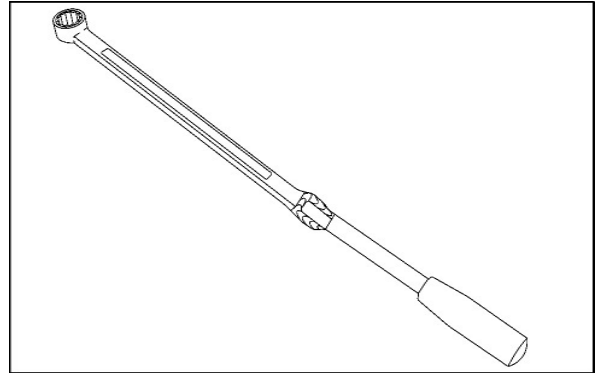

SVIL13SPT0606AB 17

Special wrench for rear wheel support fastening bolts

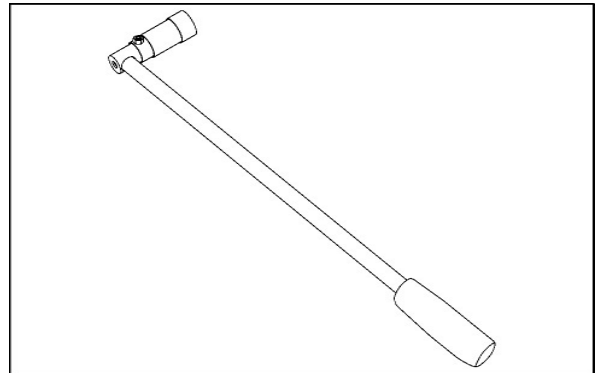

SVIL13SPT0607AB 18

Assembly tool, left, for SpeedySleeve ring

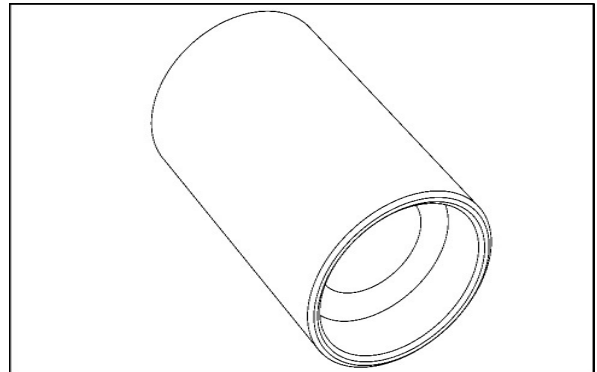

SVIL13SPT0608AB 19

Assembly tool, right, for SpeedySleeve ring

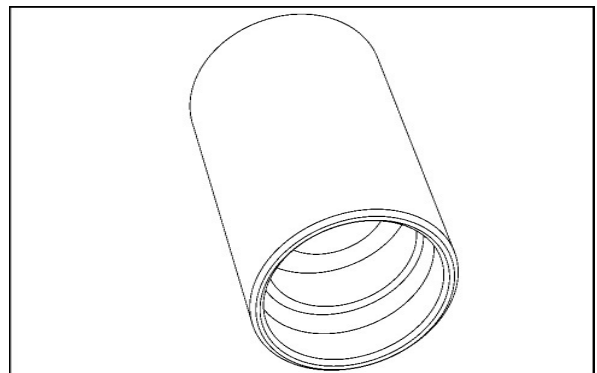

SVIL13SPT0609AB 20

## INTRODUCTION

Water tank indicator service tool

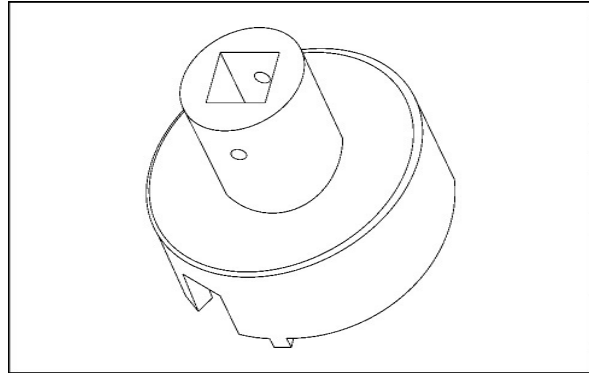

SS13A547 21

**For measuring speed and frequency**

Tachometer

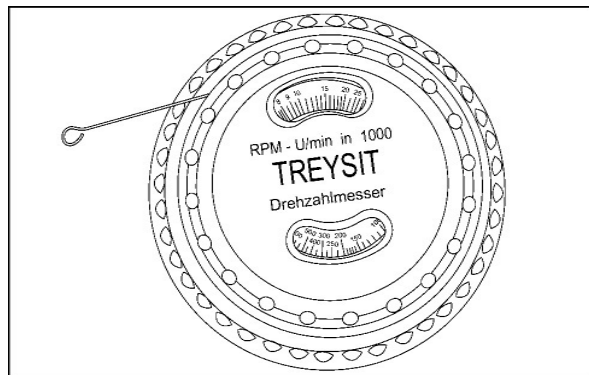

SVIL13SPT0505AB 22

**For checking solenoids**

Solenoid tester

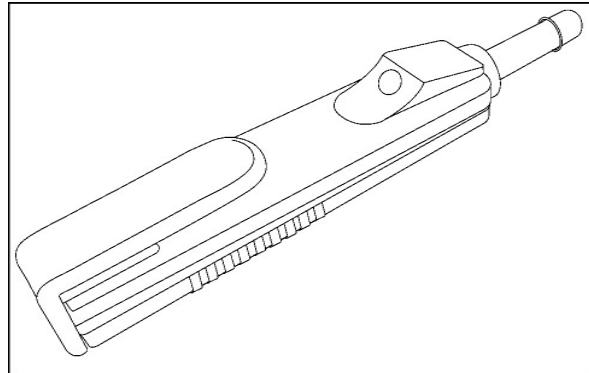

SVIL13COM0061AB 23

---

**For checking and calibrating the pump current**

Connector with jumper

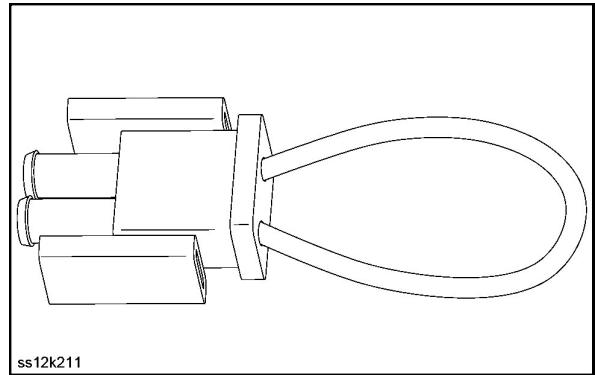

ss12k211 24

**For Servicing**

Assembly tool

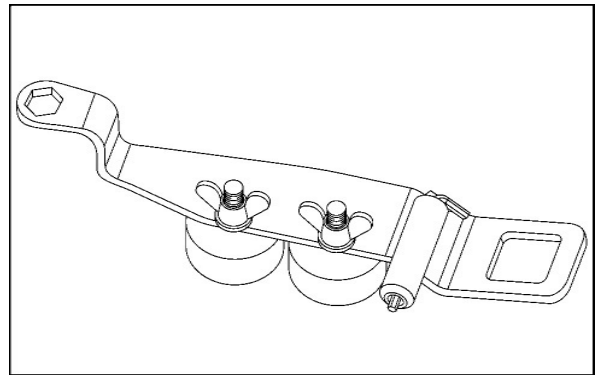

SVIL13SPT0589AB 25



---

**For drum ballast (only for DV45)**

Assembly tool for lifting the roller drum ballast.

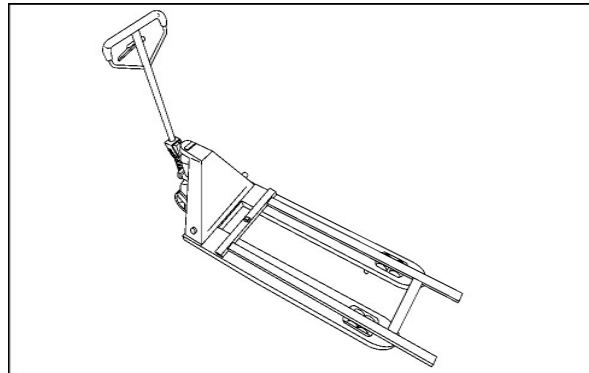

SVIL13SPT0612AB 26

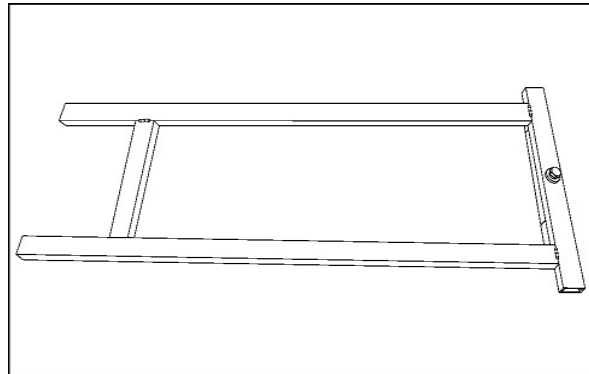

SVIL13SPT0614AB 27

THANK YOU FOR VISITE WITH

[www.repair-manuals.com](http://www.repair-manuals.com)

**DOWNLOAD THIS FULL MANUAL**

**Until download and place it on your computer We care with you ,We really try our best to complete your orders, so your review is very important to us to improve our services**

WE OFFER

ORIGINAL FACTORY MANUALS , WORKSHOP  
MANUALS , SERVICE MANUALS , REPAIR

OUR VISION : 100 % CUSTOMER SATISFACTION,  
AFTER SALE SERVICE AND KEEP IN TOUCH WITH