

Form No.
917002

SL46/4840 SL56/6640 Skid-Steer Loaders



Service Manual

GEHL[®]

INTRODUCTION

With correct maintenance and proper use, Gehl skid-steer loaders will give years of dependable service. This service manual is intended to be a guide in the assembly and disassembly, installation and removal, adjustment and testing, troubleshooting and replacement of components that together make up the Gehl 40 Series family of skid-steer loaders.

In many of the procedures found within, the installation steps are the exact opposite of the removal steps and vice versa, and therefore, the opposite procedure is not written. Instead, a note to reverse the procedure will be stated. This reduces redundancy and excessive pages in the manual. In cases though, where the assembly and disassembly or removal and installation procedures differ and additional steps or safety concerns are paramount, the entire reverse procedure will be written out to include the new information.

The Table of Contents and Index can be used to make the procedure you need to find an easier process. Also, there are black tabs extending off the pages highlighting the chapters for those who prefer to thumb through the manual. Many schematics, photographs, and line art drawings are used to help perform the necessary repairs, tests, or adjustments that the 40 Series skid-steer loaders need to keep them in good running condition.

If you have any additional questions, please contact your authorized Gehl dealer or call the Gehl Service Department for assistance.

TABLE OF CONTENTS

Specifications	Page 1-1
Specifications	1-1
Tire Options	1-1
Buckets and Capacities	1-1
Dimensional Specifications	1-2
Safety	Page 2-1
General Information	2-1
Signal Words	2-1
Additional Safety Reminders	2-1
Mandatory Safety Shutdown Procedure	2-2
Liftarm Support Device	2-3
Liftarm Support Device Engagement	2-3
Liftarm Support Device Disengagement	2-4
Rollover Protective Structure (ROPS) - Raising	2-4
Rollover Protective Structure (ROPS) - Lowering	2-5
Relieving Hydraulic Pressure	2-6
Loader Raising Procedure	2-7
Loader Lowering Procedure	2-7
Lubrication	Page 3-1
General Information	3-1
Hydraulic Oil Reservoir	3-2
Crankcase Oil	3-2
Chaincases	3-3
Grease Fitting Locations	3-3
Cooling System Drain Procedures	3-4
Mainframe	Page 4-1
Introduction	4-1
Engine Access Covers - Removal and Installation	4-2
Rollover Protective Structure (ROPS) Removal and Installation	4-6
Seat Removal and Installation	4-7
Seat Slide Replacement	4-7
Air Duct Removal and Installation	4-8
Air Duct Louver Replacement	4-8

Rollover Protective Structure (ROPS) Rear Window Removal and Installation 4-9

Restraint Bar Removal and Installation 4-11

Gehl All-Tach™, Power-A-Tach™ Hitch Removal and Installation 4-15

Liftarm Removal and Installation 4-16

Liftarm Bushing Replacement 4-19

Liftarm Stop Installation and Adjustment 4-20

Control Cover, Floor Cover Removal and Installation 4-20

Crossmember Removal and Installation 4-21

Fuel Sensor Removal and Installation 4-23

Rear Grille Removal and Installation 4-24

Rear Grille Latch Removal and Installation 4-24

Wheel Drives Page 5-1

Introduction 5-1

Drive Chain Adjustment 5-2

Axle Housing Assembly Removal and Installation 5-3

Drive Chain Removal and Installation 5-4

Axle and Wheel Bearing Disassembly and Assembly 5-6

Controls Page 6-1

Introduction 6-1

Control Handle Removal and Installation 6-6

Control Handle Position Adjustment 6-7

Control Handle Tracking Adjustment, Drive Controls 6-8

T-Bar Control Handle Assembly 6-9

Hand/Foot Control Handle Assembly 6-11

Dual Hand Control Handle Assembly 6-12

Pivot Tube Removal and Installation - T-Bar, Hand/Foot and Dual Hand 6-16

Neutral Centering Device Adjustment 6-18

Control Arm Assembly Removal and Installation 6-19

Lift/Tilt Control Removal and Installation 6-20

Lift/Tilt Control Adjustment 6-23

Auxiliary Hydraulics Cable Removal and Installation - T-Bar and Dual Hand 6-27

Auxiliary Hydraulics Cable Adjustment - T-Bar and Dual Hand 6-28

Auxiliary Hydraulics Cable Removal and Installation - Hand/foot 6-29

Auxiliary Hydraulics Cable Adjustment - Hand/foot 6-30

Hand Throttle, Rod and Cable Removal and Installation - T-Bar and Dual Hand 6-33

Foot Throttle Removal and Installation - T-Bar and Dual Hand 6-34

Hand Throttle Tension Adjustment 6-35

All-Tach is a trademark of the Gehl Company.

Hand Throttle and Throttle Cable Removal and Installation - Hand/Foot 6-36
 Hand Throttle Adjustment - Hand/foot 6-37
 Foot Throttle Adjustment - T-Bar and Dual Hand 6-38

Hydrostatic System Page 7-1

Introduction 7-1
 Troubleshooting Guide 7-7
 Charge Pressure Test and Adjustment 7-11
 Hydrostatic Pump Relief Valves 7-12
 Hydrostatic Pump Removal and Installation 7-12
 Hydrostatic Pump Drive Coupling Removal and Installation 7-14
 Drive Motor Removal and Installation 7-15

Hydraulic System Page 8-1

Introduction 8-1
 Troubleshooting Guide 8-1
 Pressure Tests, Control Valve and High-Flow 8-17
 Tilt Cylinder Test 8-19
 Self-Leveling Valve Test 8-21
 Lift Cylinder Test 8-22
 Solenoid Valve Test - Safety Lock, Brake and Two-Speed 8-23
 Hydraulic Oil Filter Element Replacement 8-25
 Tilt Cylinder Removal and Installation 8-27
 Lift Cylinder Removal and Installation 8-29
 Lift and Tilt Cylinder Disassembly and Assembly 8-32
 Gear Pump Removal and Installation 8-34
 Self-Leveling Valve Removal and Installation 8-36
 Self-Leveling Valve Adjustment 8-38
 Safety Lock Valves - Removal and Installation 8-39
 Lift and Tilt Solenoid Valves - Disassembly and Assembly 8-41
 Control Valve Removal and Installation 8-42
 High-Flow Manifold Valve Removal and Installation 8-46
 High-Flow Manifold Valve Disassembly and Assembly 8-47
 Pilot Valve Removal and Installation - Hand/Foot 8-48
 Relief Valve Removal and Installation 8-50
 Control Valve Disassembly and Assembly 8-50
 Spool Lock Solenoid Removal and Installation 8-51
 Hydraulic Tank Removal and Installation 8-43
 Hydraglide™ Accumulator Removal and Installation 8-54
 Hydraulic System Schematic, 40 Series 8-56

SPECIFICATIONS

	4640	4840	5640	6640
Make of Engine	Deutz	Deutz	Deutz	Deutz
Model	F3M2011/BF3M2011	F4M2011	F4M2011/BF4M2011	BF4M2011
Fuel	Diesel	Diesel	Diesel	Diesel
Displacement	142 CID (2,3 L)	190 CID (3,1 L)	190 CID (3,1 L)	190 CID (3,1 L)
Horsepower - Net	46/60 hp (34/45 kW) @ 2600 rpm	60 hp (45 kW) @ 2500 rpm	60/82 hp (45/61 kW) @ 2500 rpm	82 hp (61 kW) @ 2500 rpm
Peak Torque	106/140 lb-ft (144/190 N•m) @ 1700/1600 rpm	144 lb-ft (195 N•m) @ 1700 rpm	144/199 lb-ft (195/270 N•m) @ 1700/1600 rpm	199 lb-ft (270 N•m) @ 1600 rpm
Operating Load - SAE*	1500 lbs (680 kg)	1700 lbs (771 kg)	2000 lbs (907 kg)	2400 lbs (1089 kg)
Operating Weight	6200/6250 lbs (2812/2835 kg)	6480 lbs (2939 kg)	7380/7430 lbs (3348/3370 kg)	7800 lbs (3538 kg)
Shipping Weight	5715/5545 lbs (2592/2515 kg)	5825 lbs (2642 kg)	6740/6790 lbs (3057/3080 kg)	7160 lbs (3247 kg)
Hydraulic Reservoir	12 US gal (45 L)	12 US gal (45 L)	16 US gal (61 L)	16 US gal (61 L)
Engine Oil	8.3 US qts (7,9 L)	11.5 US qts (10,8 L)	11.5 US qts (10,8 L)	11.5 US qts (10,8 L)
Fuel Tank	15/17 US gal (56,8/64,4 L)	17 US gal (64,4 L)	19 US gal (71,9 L)	24 US gal (90,9 L)
Hydraulic System Pressure	2750 PSI (190 bar)	2750 PSI (190 bar)	3000 PSI (207 bar)	3000 PSI (207 bar)
Standard Aux. Flow Rate	19 gpm (72 L/min)	19 gpm (72 L/min)	23 gpm (87,1 L/min)	23 gpm (87,1 L/min)
Hi-Flow Aux. Flow Rate	30 gpm (114 L/min)	30 gpm (114 L/min)	36 gpm (136,3 L/min)	36 gpm (136,3 L/min)

Specifications below apply to all 40 Series Models	
Capacities	
Chaincases (each)	8 US qts (7,5 L)
Electrical	
Battery	12-volt DC, 950 CCA
Starter	12-volt DC (2,3 kW)
Alternator	95 A
Hydraulic System	
Travel Speed - Single Speed	0 to 8.4 mph (0 to 13,5 km/h)
Travel Speed - Two-Speed (optional on 4840, 5640, 6640)	0 to 12.5 mph (0 to 20 km/h)

Tire Options	
10 (12) x 16.5 - 8 (10) - ply	High Clearance Flotation tires
10 (12) x 16.5 - 8 (10) - ply	Heavy Duty Poly-filled tires
10 (12) x 16.5 - 8 (12) - ply	Severe Duty tires
10 (12) x 16.5 - 8 (12) - ply	Severe Duty Poly-filled tires
6.50(7.50) x 16 Solid	Solid Rubber tires
33 x 15.50 x 16.5 - 12-ply	Heavy Duty 2000 II tires
14 x 17.5 - 14-ply	High Clearance Flotation tires

Buckets and Capacities			
Width - inches (millimeters)	Bucket Description	Capacity (Heaped)	
65 inches (1651 mm)	Dirt/Construction	10.8 cubic feet	0,31 cubic meters
65 inches (1651 mm)	Dirt/Construction	14.7 cubic feet	0,42 cubic meters
68 inches (1727 mm)	Dirt/Construction	15.3 cubic feet	0,43 cubic meters
68 inches (1727 mm)	Dirt/Construction	19.0 cubic feet	0,54 cubic meters
72 inches (1829 mm)	Dirt/Construction	20.4 cubic feet	0,58 cubic meters
65 inches (1651 mm)	Utility/Snow	18.6 cubic feet	0,53 cubic meters
72 inches (1829 mm)	Utility/Snow	32.5 cubic feet	0,92 cubic meters
15.75, 19.68, 24 inches (400, 500, 610 mm)	Pallet Fork	NA	NA

*Operating load rated with a 65" inch 4640/4840 (1651 mm) dirt/construction bucket or 68" inch 5640/6640 (1727 mm) dirt/construction bucket in accordance with SAE J818.

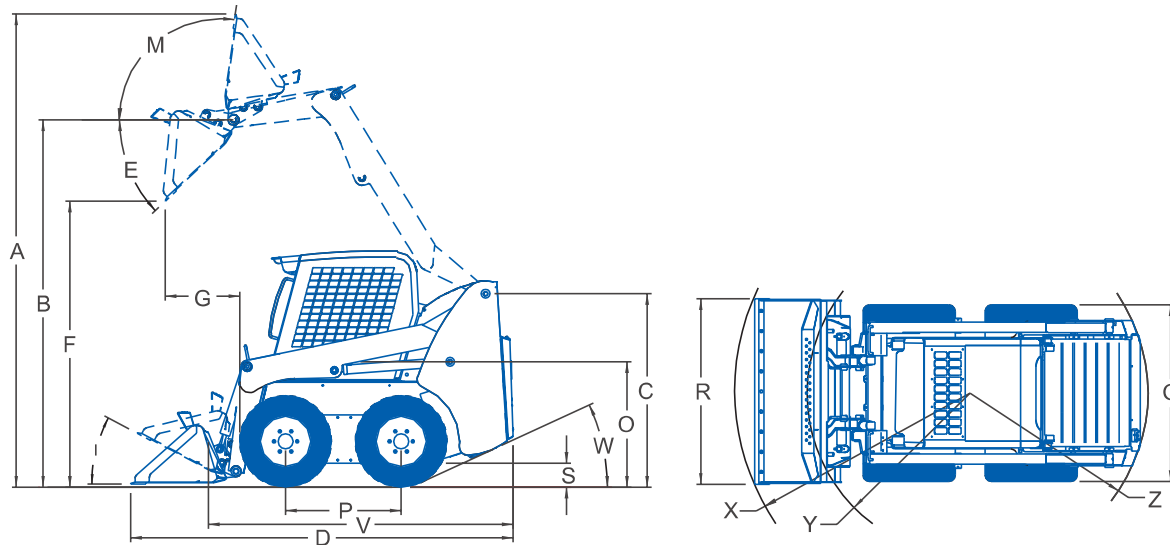

Dimensional Specifications		4640 ¹		4840 ¹		5640 ²		6640 ²	
		in.	mm	in.	mm	in.	mm	in.	mm
A	Overall operation height - fully raised	149	3785	149	3785	162	4115	167	4242
B	Height to hinge pin - fully raised	115.5	2934	115.5	2934	123	3124	123	3124
C	Overall height - top of ROPS	78	1981	78	1981	81	2057	81	2057
D	Overall length - bucket down	122.8	3118	126.3	3208	131	3327	141.5	3594
E	Dump angle @ full height	40°		40°		40°		40°	
F	Dump height	89.5	2273	89.5	2273	93.5	2375	91.25	2318
G	Dump reach - bucket (full height)	25	635	25	635	32.8	833	35.5	902
J	Rollback at ground	27°		27°		30°		30°	
M	Rollback angle at full height	86°		86°		84°		84°	
O	Seat-to-ground height	37.5	953	37.5	953	42	1067	42	1067
P	Wheelbase - nominal	37.5	953	41.5	1054	42.5	1080	48.4	1219
Q	Overall width - less bucket	63.5	1613	63.5	1613	67	1702	67	1702
R	Overall bucket width	66	1679	66	1679	70	1778	74	1880
S	Ground clearance to chassis (between wheels)	7.5	191	7.5	191	8.0	203	8.0	203
U	Maximum back grading angle	91°		91°		82°		82°	
V	Overall length (less bucket)	89.8	2291	93.3	2370	95.5	2426	101	2794
W	Departure angle	25°		25°		26°		25°	
X	Clearance circle - front (with bucket)	74.5	1892	76	1930	82	2083	89.5	2273
Y	Clearance circle - front (less bucket)	47	1194	48	1219	50.5	1283	53	1346
Z	Clearance circle - rear	59.5	1511	61.5	1562	66	1676	68	1727

1 - w/ 0.4 cu. yd. bkt., w/ 10 x 16.5 tires
 2 - w/ 0.56 cu. yd. bkt., w/ 12 x 16.5 tires



General Information

The above safety alert symbol means: ATTENTION! BECOME ALERT! YOUR SAFETY IS INVOLVED! It stresses an attitude of “Heads Up for Safety” and can be found throughout this service manual and on the decals on the machine.

Before operating or working on this machine, read and study the following safety information. In addition, be sure that every one who operates or works on this equipment is familiar with these safety precautions. It is essential to have competent and careful operators, who are not physically or mentally impaired, and who are thoroughly trained in the safe operation of the machine and the handling of loads. It is recommended that the operator be capable of obtaining a valid motor vehicle operator’s license.

The use of skid-steer loaders is subject to certain hazards that cannot be eliminated by mechanical means, but only by exercising intelligence, care and common sense. Such hazards include, but are not limited to, hillside operation, overloading, instability of the load, poor maintenance and using the equipment for a purpose for which it is not intended or designed.

The Gehl Company ALWAYS considers the operator’s safety when designing its machinery and guards exposed moving parts for the operator’s protection. However, some areas cannot be guarded or shielded in order to assure proper operation. Furthermore, the Operator’s Manual and the decals on the machine warn of additional hazards and should be read and observed closely.

This section of the manual includes procedures, which when followed, will allow safe performance of service procedures: Mandatory Safety Shutdown Procedure, Lift Cylinder Liftarm Support Device, Roll Over Protective Structure (ROPS)/Falling Object Protective Structure (FOPS) Lock Mechanism, Loader Raising and Lowering Procedures, and Relieving Hydraulic Pressure.

Signal Words



“DANGER” indicates an imminently hazardous situation which, if not avoided, will result in death or serious injury.



“WARNING” indicates a potentially hazardous situation which, if not avoided, could result in death or serious injury.



“CAUTION” indicates a potentially hazardous situation which, if not avoided, may result in minor or moderate injury. May also alert against unsafe practices.

Additional Safety Reminders



Read and understand the Service Manual and all decals before maintaining, adjusting or servicing this equipment.

Doors, Guards and Shields - Some photographs in this manual may show doors, guards and shields open or removed for illustrative purposes only. BE SURE all doors, guards and shields are in their proper operating positions BEFORE starting engine to operate unit.

Damaged or Worn-out Parts - For safe operation, replace damaged or worn-out parts with genuine Gehl service parts, BEFORE operating this equipment.

Attachments - Gehl skid-steer loaders are designed and intended to be used only with Gehl Company attachments or approved referral attachments. The Gehl Company cannot be responsible for operator safety if the loader is used with a non-approved attachment.

Battery Safety - To avoid injury from a spark or short circuit, disconnect the negative battery cable (-) before servicing any part of the electrical system. Do not tip the battery more than 45° to avoid spilling electrolyte.



Loader Stability - A skid-steer loader's stability is determined by its wheel base. The following elements can affect stability: terrain, engine speed, load being carried or dumped, and sudden control movements.

DISREGARDING ANY OF THESE FACTORS CAN CAUSE THE LOADER TO TIP, POSSIBLY RESULTING IN DEATH OR SERIOUS INJURY. Therefore, ALWAYS have the operator restraint bar lowered and wear the seat belt. Operate the controls only from the operator's seat. Operate the controls smoothly and gradually at an appropriate engine speed that matches the operating conditions.

DO NOT exceed the rated operating load of the machine. For additional stability when operating on inclines or ramps, ALWAYS travel with the heavier end of the loader toward the top of the incline.

ALWAYS look to the rear before backing up.

When parking machine, before leaving seat, check restraint bar for proper operation. The restraint bar, when raised, applies parking brake and deactivates lift/tilt controls and auxiliary hydraulics.

Keyswitch - NEVER attempt to bypass the keyswitch to start the engine. Use the jump-starting procedure detailed in the *Service* chapter of your Operator's Manual.

Hydraulic Fluid Leaks - NEVER use hands to search for hydraulic fluid leaks. Instead, use paper or cardboard. Fluid under pressure can be invisible, penetrate the skin and cause a serious injury. If any fluid is injected into skin, see a doctor at once. Injected fluid MUST be surgically removed by a doctor or gangrene may result.



Wear Safety Glasses - ALWAYS wear safety glasses with side shields when operating the machine or striking metal against metal. In addition, it is recommended that a softer (chip-resistant) material be used to cushion the blow. Failure to heed could lead to serious injury to eye(s) or other parts of the body.



ALWAYS wear safety glasses when searching for hydraulic leaks or when working near batteries.

Loaded Bucket/Fork - DO NOT raise or drop a loaded bucket or fork suddenly. Abrupt movements under load can cause serious loader instability.

NEVER push the lift control into the "float" position with the bucket or attachment loaded or raised, because this will cause the liftarm to lower rapidly.

DO NOT drive too close to an excavation or ditch. BE SURE that the surrounding ground has adequate strength to support the weight of the loader and the load.



DO NOT smoke or have any spark producing equipment in the area while filling the fuel tank or while working on the fuel or hydraulic systems.

Exhaust Gases - Exhaust fumes can kill. DO NOT operate this machine in an enclosed area unless there is adequate ventilation.

Engine - NEVER use ether or starting fluid.

People - NEVER carry riders. DO NOT allow others to ride on the machine or attachment, because they could fall or cause an accident.

BE SURE all persons are away from the machine and give a warning before starting the engine.

ALWAYS face machine and use hand holds and steps when getting on or off. DO NOT jump off machine.



Wear appropriate ear protection for prolonged exposure to excessive noise.

ALWAYS perform a daily inspection of the machine BEFORE using it. Look for damage, loose or missing parts, leaks, etc.

Remove trash and debris from the machine and engine compartment each day to minimize risk of fire.

New operators MUST operate loader in an open area away from bystanders. Practice with controls until loader can be operated safely and efficiently.

Mandatory Safety Shutdown Procedure

BEFORE cleaning, adjusting, lubricating, or servicing the unit or leaving it unattended:

1. Move the drive control handle(s) to the NEUTRAL position.
2. Lower the liftarm and attachment completely.
3. Move the throttle to the low idle position, shut off the engine and remove the key.
4. However, if the liftarm MUST be left in the "raised" position, BE SURE to properly engage the liftarm support device.

Only after these precautions can you be sure it is safe to proceed. Failure to follow the above procedure could lead to death or serious injury.

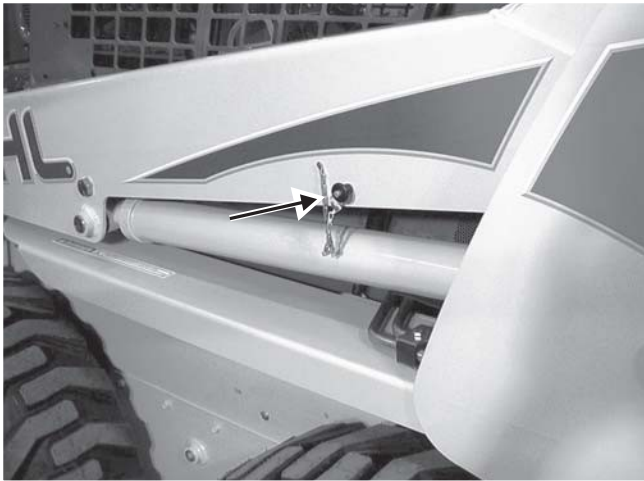

Fig. 2-1 The lock pin secures the liftarm support device inside the left liftarm.



Fig. 2-2 Press in and hold the lock pin button and pull it out.

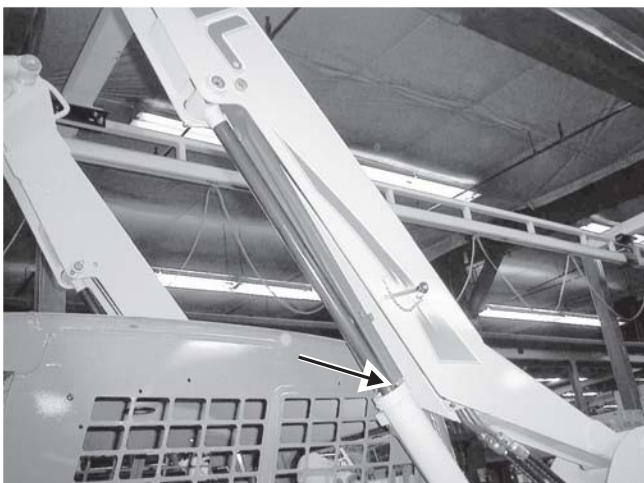

Fig. 2-3 The liftarm support device rests on top of the lift cylinder base.

Liftarm Support Device

WARNING

BEFORE leaving the operator's compartment to work on the loader with the liftarm raised, **ALWAYS** engage the liftarm support device. Turn the keyswitch to OFF, remove the key and take it with you.

Many service procedures require a raised liftarm to allow easier access to loader components. For operator and service personnel safety, a liftarm support device is standard on GEHL skid-steer loaders. Used as a cylinder block, it helps prevent a raised liftarm from unexpectedly lowering.

BE SURE to engage the liftarm support device whenever the liftarm is raised. When the device is not being used, secure it to the anchor on the underside of the liftarm using the lock pin and retainer provided.

The liftarm support device is a safety device which must be kept in proper operating condition at ALL times.

The following procedures outline the correct way to engage and disengage the liftarm support device.

Liftarm Support Device Engagement

1. Lower liftarm until contact with loader frame.
2. Turn the keyswitch to the OFF position to stop the engine.
3. Leave operator's compartment. Press in and hold lock pin button to release its locking mechanism. Remove lock pin holding support device up against liftarm. Allow support device to come down into contact with lift cylinder. **Figs. 2-1 and 2-2**
4. Return to the operator's compartment and restart the engine.
5. Use lift control to raise liftarm until lift arm support device drops over the end of the lift cylinder and around cylinder rod. Slowly lower liftarm until free end of support device contacts top end of lift cylinder. **Figs. 2-3 and 2-4**
6. Make sure the support device is secure against the cylinder end. Then, stop the loader engine, remove the key and leave the operator's compartment.

Liftarm Support Device Disengagement

WARNING

NEVER leave the operator's compartment to disengage the liftarm support device with the engine running.

To return the liftarm support device to its storage position, proceed as follows:

1. Raise the liftarm completely.
2. Turn the keyswitch to the OFF position to stop the engine, remove the key and take it with you.

WARNING

BEFORE testing the machine, **ALWAYS** clear people from the area.

3. Before leaving the operator's compartment, check to be sure the liftarm is being held in the raised position by the solenoid valve (See NOTE).

NOTE: With the keyswitch OFF, and the solenoid valve functioning properly, the liftarm will not move when the lift control is moved forward. If the valve does NOT hold the liftarm, do NOT leave the operator's compartment. Instead, have someone store the support device for you. Then, contact your Gehl dealer to determine the reason why the liftarm lowers while the keyswitch is in the OFF position.

4. To store liftarm support device, lift it up and inside the liftarm. Insert lock pin through the hole in the liftarm and through the support device. **Fig. 2-4**

ROPS – Raising

For service, the ROPS can be unbolted and tilted back. Gas-charged springs help tilt it back. A self-actuating lock mechanism engages to lock the ROPS in a rolled-back position.

1. The liftarm should be lowered or locked in the raised position as per the "Liftarm Support Device Engagement" procedure in this chapter.
2. Turn the keyswitch to the OFF position to stop the engine. Remove the key and take it with you.
3. Leave the operator's compartment.



Fig. 2-4 Secure the liftarm support device in its storage position with liftarm fully raised, then lower liftarm.

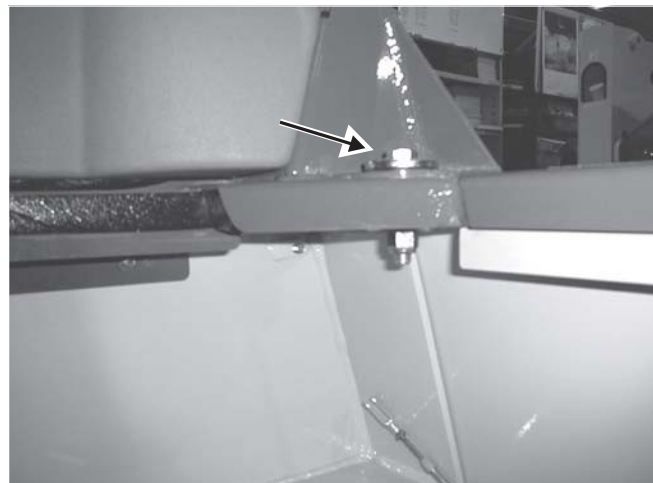

Fig. 2-5 Front left ROPS mounting area where the ROPS is secured to the chassis. Right side same.



Fig. 2-6 Use wrenches to release the front of the ROPS from the chassis.



Fig. 2-7 Location of the self-actuating lock mechanism.

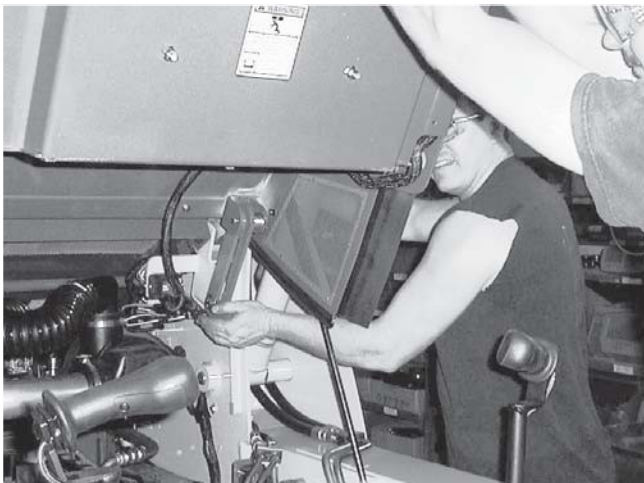

Fig. 2-8 Lowering the ROPS is a two-person operation.

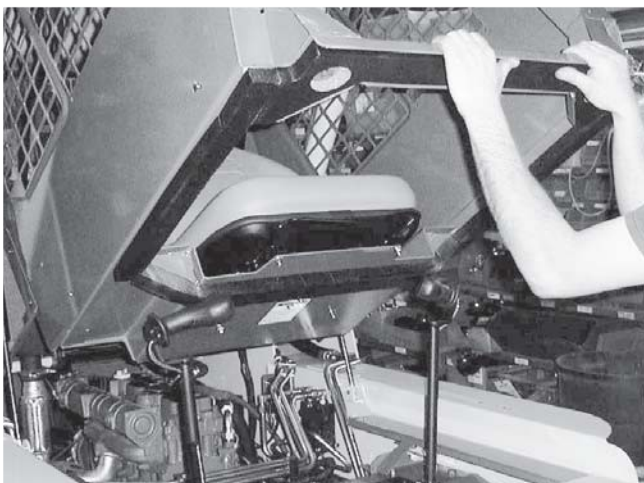

Fig. 2-9 BE SURE the ROPS/FOPS clears the control handles.

WARNING

DO NOT leave the operator's compartment with the engine running. Before leaving the loader shut off the engine according to the "Mandatory Safety Shutdown Procedure" described in this chapter.

4. Remove one capscrew, three flat washers, and one locknut on each side of the ROPS. **Fig. 2-6**
5. Lift ROPS up and tilt it back until the self-actuating lock mechanism engages. The lock mechanism locks the ROPS in a rolled-back position. **Fig. 2-7**

IMPORTANT

BEFORE raising the ROPS, position the seat as far back as it will go. Avoid damaging control handles by slowly raising the ROPS. **BE SURE** the control handles clear the ROPS.

ROPS – Lowering

1. With an assistant's help, apply upward force on the ROPS while assistant pulls the lock mechanism handle toward the front of the loader. **Fig. 2-8**
2. Lower ROPS until it contacts with the chassis. **Fig. 2-9**

IMPORTANT

Avoid damaging control handles by slowly lowering the ROPS. **BE SURE** the control handles clear the ROPS.

3. Reinstall the two capscrews, six flat washers and two locknuts that attach the ROPS front uprights to the chassis. **Fig. 2-6**

Relieving Hydraulic Pressure

The following procedure should be used to relieve pressure in the hydraulic system prior to performing service procedures on hydraulic system components.

1. Completely lower the bucket or attachment.
2. Turn keyswitch to OFF position to shut down engine.
3. With the operator in the seat and the restraint bar lowered, turn the keyswitch to the ON position but DO NOT start the engine.
4. Move the lift, tilt and auxiliary hydraulics controls through several cycles. **Figs. 2-10, 2-11, 2-12**
5. Turn the keyswitch to the OFF position.

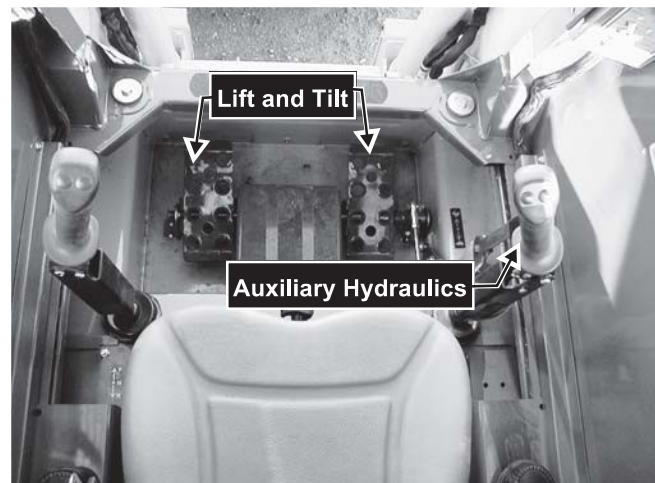

Fig. 2-10 On Hand/Foot models, the lift and tilt functions are controlled with the foot pedals on the floor of the ROPS. The auxiliary hydraulics are controlled in the right control handle.

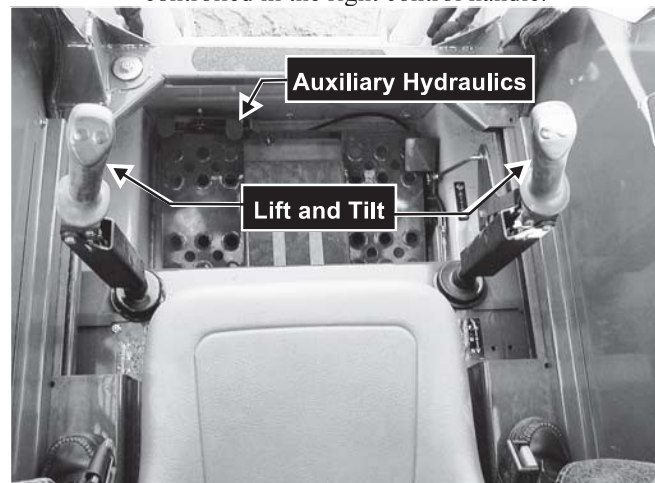

Fig. 2-11 On Dual Hand models, lift and tilt functions are controlled by the left and right control handles. The auxiliary hydraulics are controlled with the left foot on the auxiliary pedal assembly.

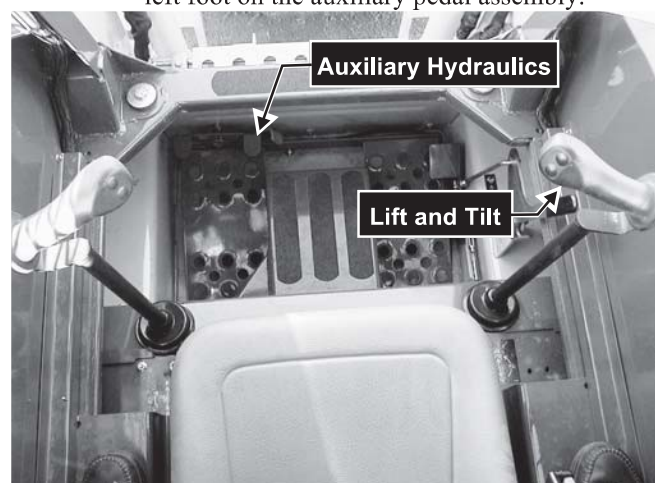

Fig. 2-12 On T-Bar models, lift and tilt functions are controlled with the right control handle. The auxiliary hydraulics are controlled with the left foot on the auxiliary pedal assembly.



Fig. 2-13 View of the stand placement and tie down support locations.



Fig. 2-14 Locations underneath the skid loader to position stands or blocks at the front and rear. (View is from the rear of the loader.)

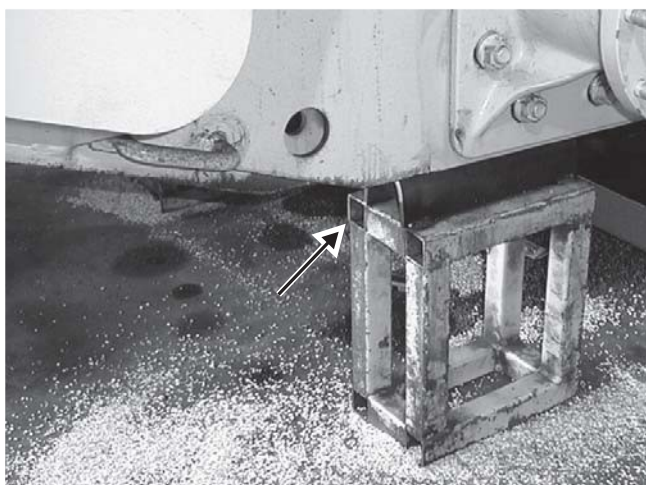

Fig. 2-15 View of stand supporting right rear of skid-steer loader.

Loader Raising Procedure

The following procedure is used to raise the skid-steer loader so that all four tires ARE NOT contacting the ground.

! WARNING

BEFORE servicing the machine, exercise the “Mandatory Safety Shutdown Procedure” described in this chapter.

! WARNING

DO NOT rely on a jack or hoist to maintain the “raised” position without additional blocking and supports. Serious personal injury could result from improperly raising or blocking the skid-steer loader.

1. To raise and block the skid-steer loader, obtain four jack stands or wooden blocks of sufficient strength to support the loader.
2. Using a jack or hoist capable of raising the fully-equipped loader, lift rear of loader until tires are off ground. **Fig. 2-14**
3. Place two jack stands under flat part of loader chassis. Place them parallel with, but not touching, the rear tires. **Fig. 2-15**
4. Slowly lower loader so its weight rests on jack stands or the wooden blocks.
5. Repeat steps 2-4 for the front end. When the procedure is finished, all four tires are off the ground, and they can be removed as necessary.

Loader Lowering Procedure

When service procedures are complete, the skid-steer loader can be taken down from the “raised” position. To lower the loader onto its tires:

1. Using a jack or hoist, raise front of loader until its weight no longer rests on the jack stands.
2. Carefully remove jack stands or wooden blocks under front of loader.
3. Slowly lower loader until front tires are on ground.
4. Repeat steps 1-3 for rear of loader.

THANK YOU FOR VISITE WITH

www.repair-manuals.com

DOWNLOAD THIS FULL MANUAL

Until download and place it on your computer We care with you ,We really try our best to complete your orders, so your review is very important to us to improve our services

WE OFFER

ORIGINAL FACTORY MANUALS , WORKSHOP
MANUALS , SERVICE MANUALS , REPAIR

OUR VISION : 100 % CUSTOMER SATISFACTION,
AFTER SALE SERVICE AND KEEP IN TOUCH WITH